

BAL SEAL® SEALS IN PRESSURE-RELIEF VALVES

Relief valves are used in hydraulic circuits that incorporate a positive displacement pump, such as a gear, vane, or piston pump. Reliability and performance are critical because these applications are connected across a pump pressure line and act as a safety valve to protect the pump.

Bal Seal® seals have repeatedly proven their performance in these types of critical applications. Bal Seal Engineering, Inc. continues to improve seal designs and material technology for improved sealing, lower stress concentration and longer seal life.

In addition, Bal Seal high-performance PTFE blends, ultra-high molecular weight polyethylene, and other materials are highly reliable in applications with abrasive environments.

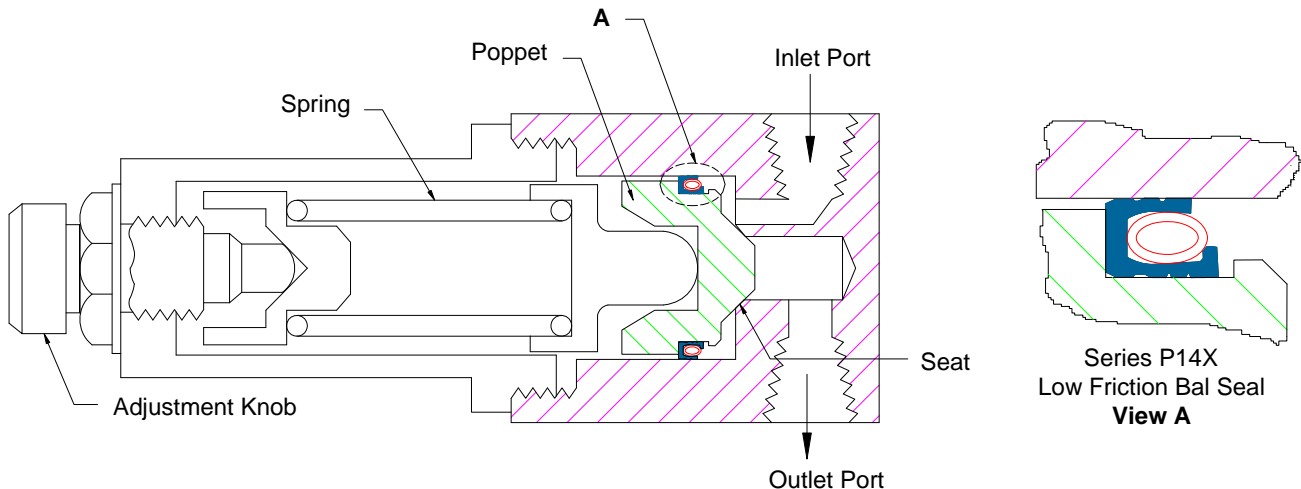

Operating Parameters

Sealing pressure:	3,000 psi (211 kg/cm ²)
Typical speed:	Slow
Temperature:	- 70 °F to 250 °F (- 57 °C to 121 °C)
Media:	Hydraulic oil
Additional:	Reliability, sealing ability and low friction

Seal Selection: P14X series

Features:

- The P14X series short-lip seals are specifically designed to mount into low-step piston grooves, which saves manufacturing and assembly costs
- Short-lip seals have outside and inside diameter sealing grooves that retain lubricants and act as additional sealing features which continue to work as the seal wears
- Canted-coil spring energizer provides near-constant force over the spring deflection range, ensuring low frictional drag, consistent sealing, and long life
- Filled PTFE seal materials provide excellent wear resistance and chemical compatibility - other high-temperature engineered plastic compounds available for reliable, long-term service

For more information and technical assistance, contact a technical sales representative.

PATENTS: The items described in this page include products that are the subject of issued United States and foreign patents or products where patents are pending, including the following: Patents 6,641,141 B2; 7,210,398 B2; 6,161,838; 5,992,856; 5,134,244

U.S. Address 19650 Pauling Foothill Ranch, CA 92610-2610 • Phone: (949) 460-2100 • Fax: (949) 460-2300

BV Address: Jollemanhof 16, 5th floor • 1019 GW Amsterdam • The Netherlands • Phone: 31 20 638 65 23 • Fax: 31 20 625 60 18

Rev.D 8-30-07 (11-188)

www.balseal.com