

OPTIONAL QUALITY ASSURANCE PROCEDURES AND DOCUMENTATION

Technical Report
TR-31 (Rev. B; 04-13-01)
(100-76, 100-76-1)



19650 Pauling
Foothill Ranch, CA 92610-2610
Tel (949) 460-2100
Fax (949) 460-2300
Email: sales@balseal.com
www.balseal.com

Bal Seal Engineering Europe B.V.
Jollemanhof 16, 5th Floor
1019 GW Amsterdam
The Netherlands
Tel +31 20 638 6523
Fax +31 20 625 6018
Email: ordersbv@balseal.nl

TABLE OF CONTENTS

- 1.0 Discussion
- 2.0 Seal friction force testing
 - 2.1 Method used to measure frictional seal force
 - 2.2 Individual seal test results
 - 2.3 Batch analysis of seal forces
 - 2.4 Method used to measure radial frictional spring force
 - 2.5 Individual spring test results
 - 2.6 Batch analysis of spring forces
- 3.0 Quality control of BAL™ Seal springs
- 4.0 PTFE and PTFE composition tensile, elongation and specific gravity

The information, descriptions, recommendations and opinions set forth herein are offered solely for your consideration, inquiry, and verification and are not, in part or in whole, to be construed as constituting a warranty, expressed or implied, nor shall they form or be a part of the basis of any bargain with Bal Seal Engineering. If any sample or model was shown to or provided by Buyer/User, such sample or model was used merely to illustrate the general description and type of goods. Such use is not to be construed as a warranty that the goods will conform to the sample or model. Furthermore, THE IMPLIED WARRANTY OF MERCHANTABILITY AND FITNESS FOR A PARTICULAR PURPOSE AND ALL OTHER WARRANTIES, IMPLIED OR EXPRESSED, ARE EXCLUDED AND SHALL NOT APPLY. This document provides product options for further investigation by Buyers/Users having technical expertise. The Buyer/User, through its own analysis and testing, is solely responsible for making the final selection of the products and for assuming that all performance, safety and warning requirements for the application are met. It is recommended that Buyers/Users run evaluation testing under actual service conditions to determine whether proposed Bal Seal products are suitable for the intended purpose. Nothing contained herein or in any of our literature shall be considered a license or recommendation for any use that may infringe patent rights. (LE-17)

PATENTS: The items described in this report include products that are the subject of the following issued United States patents: 5,979,904; 5,994,856; 6,050,572; 5,984,316; 6,161,838 and others, as well as foreign patents or products where patents are pending. (LE-88G)

©Copyright 2001, Bal Seal Engineering Co., Inc. U.S.A.

Use or disclosure of data contained on this sheet is subject to the restrictions contained in the disclaimer located in the Table of Contents of this report.

1.0 DISCUSSION

BAL™ Seal springs, seal assemblies, and bar stock are inspected for certain dimensions and quality. As to Bal Seal Engineering's standard quality control procedures, various types of optional quality control procedures and documentation are available at extra cost to meet specific customer requirements.

The following procedures are available:

- Measuring the seal force of each individual seal and providing a computer printout
- Measuring the force of each spring and providing a computer printout
- Batch analysis of the seal forces by lot and providing a computer printout
- Batch analysis of all spring forces by lot and providing a computer printout
- Counting the number of coils on each spring
- Analyzing the weld of each spring weld
- Reporting spring wire tensile and elongation with support charts
- Other customer requirements

2.0 SEAL FRICTION FORCE TESTING

Force testing can be implemented as part of the quality control procedure in order to maintain greater consistency to achieve customer seal requirements. A specified seal force may be met by changing to a load spring having a higher or lower force, depending on requirements. BAL Seals are available in various spring forces, such as light, medium, and heavy, and the force determines to a great extent the sealing ability, friction, and seal life.

Figure 1 shows three springs, which typify the unique properties of BAL Seal canted-coil springs. Note that an increase in deflection does not cause a proportional increase in load, but rather the force tends to remain relatively constant over a wide deflection range (in this case, from 5% to 30%). This allows for variations due to wear, eccentricities, tolerance variations, and other irregularities and at the same time maintain essentially the same spring force.

BAL™ SEAL PARTS AVAILABLE TO MEET MOST FRICTION FORCE OR TORQUE REQUIREMENTS.

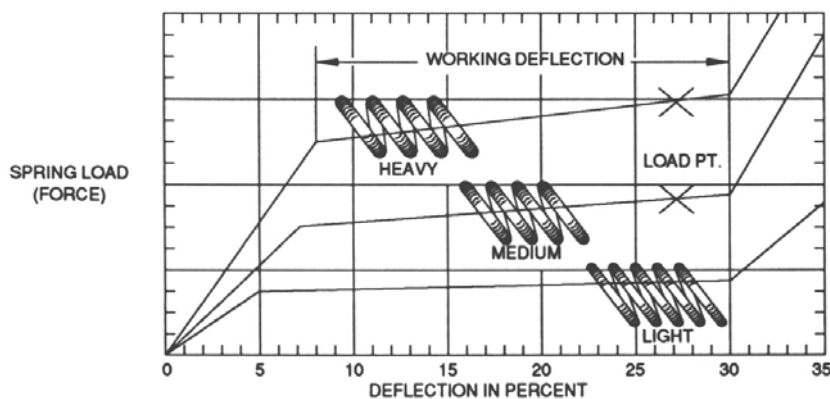

Various Types of Springs with Variable Force
FIGURE 1

Use or disclosure of data contained on this sheet is subject to the restrictions contained in the disclaimer located in the Table of Contents of this report.

2.1 Method used to measure frictional seal force

To measure seal force on the I.D., a plug gage (or customer-supplied gage) is passed through the I.D. of the seal. (See Figure 2). A similar method is used for measuring the OD seal frictional force. A computer reads the load to move the plug and plots it as a function of the time or distance traveled. The average force is then saved for a batch analysis. Maximum and minimum force values are also supplied.

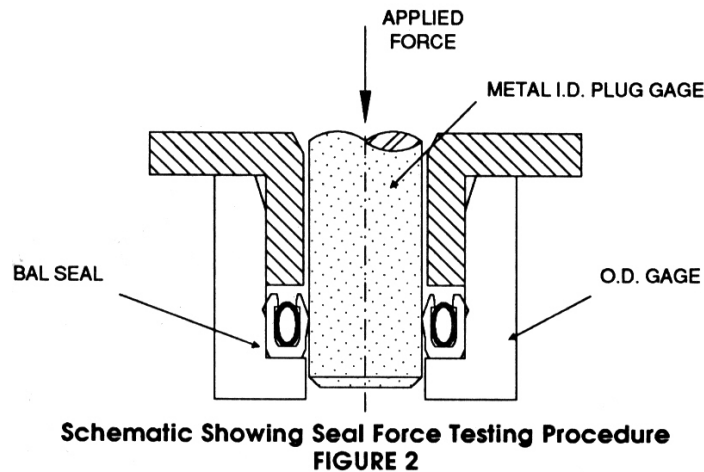

2.2 Individual seal test results

A computer readout shows the seal force measured while moving the plug gage at specified rate (Figure 3). The seal force, measured in grams, is plotted as a function of distance traveled. The test is based on a pass/fail mode. The seal will pass if the force falls within the specified tolerance range per the acceptance criteria noted below.

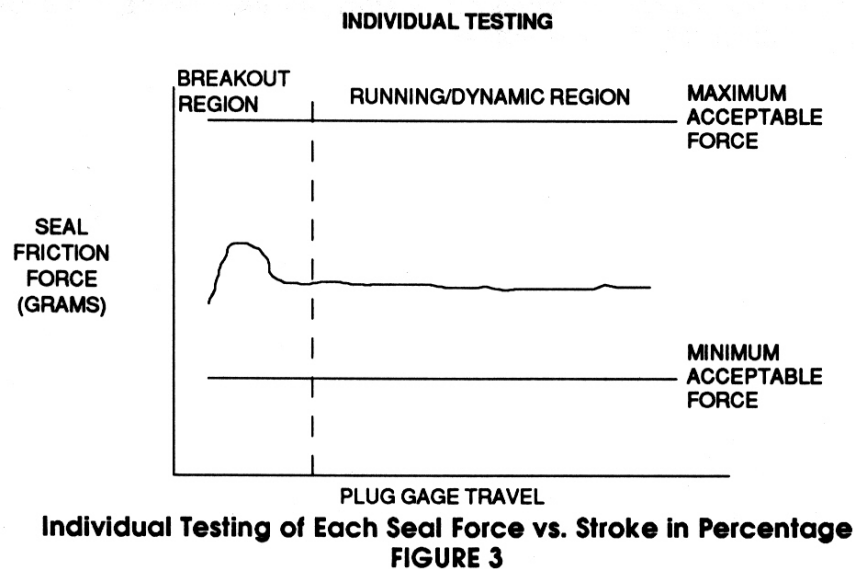

Use or disclosure of data contained on this sheet is subject to the restrictions contained in the disclaimer located in the Table of Contents of this report.

2.3 Batch analysis of seal forces

A computer readout of the average force values of the seals after individual testing is shown in Figure 4. It points out the developed seal forces of the entire batch within the maximum/minimum force tolerances.

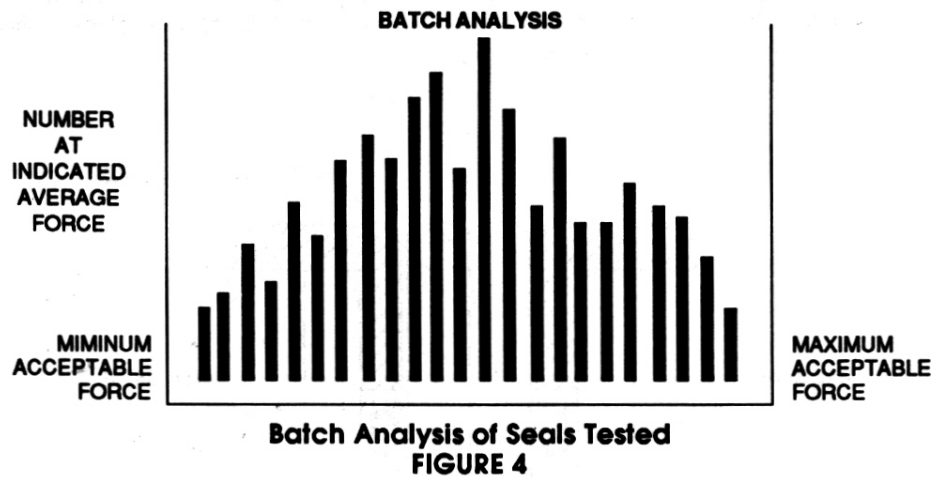

2.4 Method used to measure radial frictional spring force

To measure radial spring force on the ID, a plug gage (or customer-supplied gage) is passed through the ID of the spring (see Figure 5). A computer reads the load to move the plug and plots it as a function of the time or distance traveled. The average force is then saved for a batch analysis. Maximum and minimum force values are also supplied.

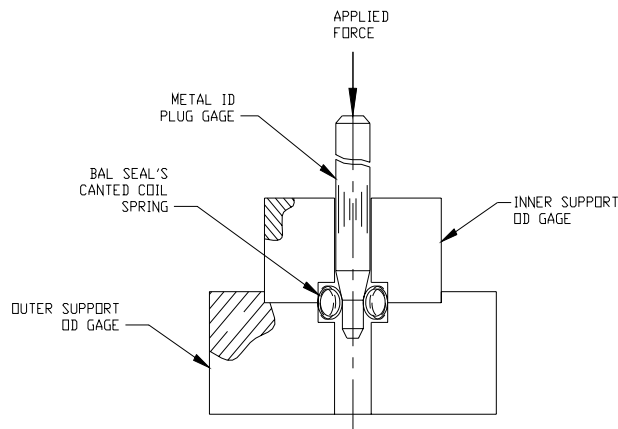

Figure 5

Use or disclosure of data contained on this sheet is subject to the restrictions contained in the disclaimer located in the Table of Contents of this report.

2.5 Individual spring test results

A computer readout shows the spring force measured while moving the plug gage (Figure 6). The spring force, measured in grams, is plotted as a function of a distance traveled. The test is based on a pass/fail mode. The spring will pass if the force falls within the specified tolerance range per the acceptance criteria noted below.

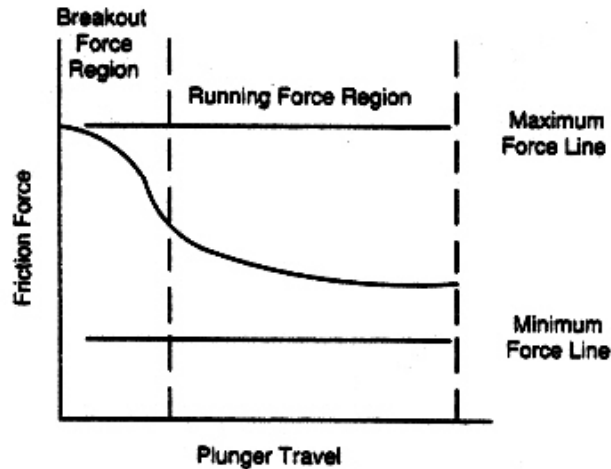

Figure 6

2.6 Batch analysis of spring forces

Bal Seal Engineering Company supplies a batch analysis (Figure 7) with each shipment of springs having a force requirement. A computer readout of the average force values of the springs after individual testing is shown in Figure 7. It points out the developed spring forces of the entire batch within the maximum/minimum force tolerances.

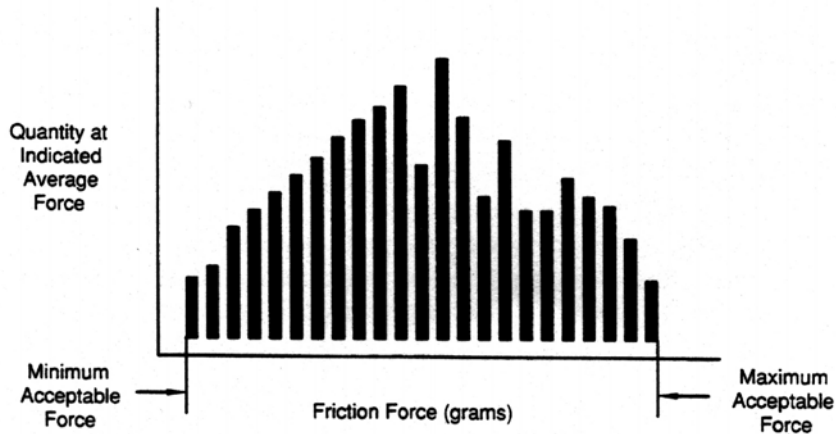

Figure 7

3.0 QUALITY CONTROL OF BAL™ SEAL SPRINGS

Dimensional inspection and visual inspection of the weld can be supplemented by computerized friction force testing of individual springs; batch analysis of spring forces for an entire lot; counting of spring coils, microscopic weld analysis; tensile and elongation data of spring wire, etc.

4.0 PTFE AND PTFE COMPOSITION TENSILE, ELONGATION AND SPECIFIC GRAVITY

The above mechanical properties can be furnished on the products being supplied by making and testing specimens from the material to be used in the fabrication of our products per ASTM and Bal Seal Engineering's general specifications.

Consult our technical sales department concerning the establishment of quality assurance procedures, testing and documentation.